

Let's gather here,  
in Yokohama!



# MBSJ 2025

President:  
Takehiko Kobayashi  
(The University of Tokyo)

The 48th Annual Meeting  
of the Molecular Biology Society of Japan

**December 3-5**  
at Pacifico Yokohama



Abstract Submission

July 1- July 31, 2025

Early Registration

July 1- October 1, 2025

# Cancellation Policy

After an application has been accepted, cancellations are generally not allowed unless the Organizing Committee determines that the cancellation is due to force majeure. If the Organizing Committee approves the cancellation, the applicant must submit a written explanation of the cancellation reasons. The cancellation fee will be calculated based on the date the cancellation notice is received.

## [Cancellation Fees]

If the cancellation notice is received *before* the application deadline ... **50%** of the invoiced amount

If the cancellation notice is received *on or after* the application deadline ... **100%** of the invoiced amount

\* The organizer reserves the right to terminate the annual meeting early, postpone, scale it down, relocate, or cancel it due to force majeure, such as natural disasters, acts of terrorism, pandemics, or other circumstances beyond the organizer's control. The organizer shall not be liable for any damages incurred by sponsoring companies as a result of these changes.

\* If the annual meeting is canceled or its format is changed due to the reasons mentioned above, the organizer will calculate the sponsorship fee after deducting preparation costs and either bill or refund the difference to the sponsoring companies. The adjusted amount will be calculated retroactively, based on the period from the originally scheduled meeting dates to the date of cancellation or format change.

# Schedule \*Tentative Schedule as of October, 2024

## MBSJ2025 Schedule Overview \*tentative

	8	9	10	11	12	13	14	15	16	17	18	19	20	21
12/3 (Wed)			Symposium (120 min) 9:00-11:00			Bio-tech Seminar (50 min) 12:20-13:10		Symposium (120 min) 13:40-15:40					Forum (75 min) 19:15-20:30	
		Symposium (80 min) 9:00-10:20	Symposium (80 min) 10:35-11:55	MBSJ Program (75 min) 12:10-13:25						Science Pitch 16:00- 17:00	Poster Discussion (120 min) 17:00-19:00	re m o v a l	Matching Event (75 min) 19:15-20:30	
		Set up												
		Exhibits 11:00-19:00												
12/4 (Thu)			Symposium (120 min) 9:00-11:00			Bio-tech Seminar (50 min) 12:20-13:10		Symposium (120 min) 13:40-15:40					Forum (75 min) 19:15-20:30	
		Symposium (80 min) 9:00-10:20	Symposium (80 min) 10:35-11:55	MBSJ Program (75 min) 12:10-13:25						Science Pitch 16:00- 17:00	Poster Discussion (120 min) 17:00-19:00	re m o v a l	Matching Event (75 min) 19:15-20:30	MBSJ General Assembly
		Set up												
		Exhibits 11:00-19:00												
12/5 (Fri)			Symposium (120 min) 9:00-11:00			Bio-tech Seminar (50 min) 12:20-13:10		Symposium (120 min) 13:40-15:40					Open Lecture (75 min) 19:15-20:30	
		Symposium (80 min) 9:00-10:20	Symposium (80 min) 10:35-11:55	MBSJ Program (75 min) 12:10-13:25						Science Pitch 16:00- 17:00	Poster Discussion (120 min) 17:00-19:00	re m o v a l		
		Set up												
		Exhibits 11:00-19:00												
		Exhibit Visit												
		Presentations by High School Students 17:00-19:00												

# List of Sponsorship Opportunities

## Luncheon Seminar and Exhibition Package

★ Luncheon Seminar and Exhibition Package (MBSJ Package)

## Seminar

Biotechnology (Luncheon) Seminar

Advance reservation is available

Biotechnology Short Seminar

Advance reservation is NOT available

Night Café Seminar

Advance reservation is NOT available

## Exhibition

★ Prime Plan [with Business Lounge Space]

★ Standard Plan [with Exhibitor Seminar]

Basic Plan (3 types)

Seminar Plan (3 types)

New Exhibitor Plan

Dedicated Sponsors Over The Years

## Advertising Opportunities

Photo Spot Advertisement

Signboard Advertisement

in front of Lecture Rooms

Wi-Fi Signboard Advertisement

Exhibition Hall Map Advertisement

Screen Advertisement

Push Pin Container Sponsor

Banner Advertisement  
on the Annual Meeting Website

Spot Advertising before and after Lectures

Email Marketing

Pocket Program Advertisement

## ★ Luncheon Seminar and Exhibition Package (MBSJ Package)

The MBSJ Package is designed for companies that wish to participate in both the luncheon seminar and the exhibition. This package includes high-exposure advertisements, providing a cost-effective and efficient way to promote your company.

<b>Eligibility</b>	Instruments, reagents, products, services, and books related to life science research Joint usage, introduction, and recruitment of universities and research institutions
<b>Number of Slots Available</b>	3 days 6 slots * Tentative
<b>Contents</b>	<p>&lt; <b>NEW! Special Benefit for MBSJ Package</b> &gt;</p> <p><b>★ Right to designate the date and venue for Luncheon Seminar ★</b> You have the right to select the date and venue for the Biotechnology (Luncheon) Seminar.</p>
	<p><b>1. 1 Biotechnology (Luncheon) Seminar</b> You can organize a seminar with lunch boxes provided. For more details, please refer to page 7.</p>
	<p><b>2. 1 or 2 Exhibition Booths (Type AS / Seminar Plan)</b> For more details, please refer to page 20.</p>
	<p><b>3. Screen Advertisement</b> Your advertisement will be projected on the screen only on the seminar date during program breaks. For more details, please refer to page 25.</p> <p><b>4. Banner Advertisement on the Annual Meeting Website</b> Your banner advertisement will be displayed on the annual meeting website. For more details, please refer to page 25.</p>
<b>Fee</b>	<p>● For 1 exhibition booth Regular price <del>2,008,000 JPY</del> ⇒ <b>1,760,000 JPY</b> (Incl. tax) + Food and drink fees</p> <p>● For 2 exhibition booths Regular price <del>2,536,000 JPY</del> ⇒ <b>2,200,000 JPY</b> (Incl. tax) + Food and drink fees</p> <p>* Room, equipment (projector, screen, microphones and audio equipment etc.) are included. * Food, drink and option fees are not included.</p>
<b>Application</b>	<p>Please apply via the online application form on the annual meeting website.</p> <p>* If you are considering applying for both the Exhibition Plan (Prime/Standard) and the MBSJ Package, please contact the secretariat.</p>
<b>Application Deadline</b>	<b>June 30, 2025 *Tentative</b>

Save approx.  
**250,000 JPY!**

Save approx.  
**340,000 JPY!**

### Distribution of seminar tickets

Currently under consideration for **advance reservations and on-site distribution** (as of December, 2024; subject to change due to operational reasons).

The lunch boxes for the Biotechnology Seminar will be distributed in exchange for seminar tickets.

\* The co-hosts will be provided with the registration information of those who have made advance reservations for the seminar.

## ★ Luncheon Seminar and Exhibition Package (MBSJ Package)

### What is included in the fee

- 1) Room fee
- 2) Basic equipment and facilities (LCD projector, screen, audio equipment, and laser pointer)
- 3) 1 operation support staff: For projection operation, time keeping, and lighting
- 4) Equipment: Desk light, bell, stopwatch, and a table for distributing handouts, box lunches, etc.
- 5) 3 meeting passes  
\* Note: If the requested speaker is a member of MBSJ, we kindly ask that the speaker complete their registration.
- 6) 10 staff badges (Separate from the exhibitor badges).

If more than one company applies for the same slot, items 5) and 6) above will be distributed to the representative company.

### What is NOT included in the fee

- 1) Equipment other than those listed above, such as equipment for filming and recording.  
Please bring your own PC for the presentation and ensure the LCD projector connection and functionality are checked.
- 2) Operation staff: For distributing box lunches and making announcements.
- 3) Food and drink: The quantity will be determined by the co-hosting companies, and the secretariat will place a bulk order accordingly.  
(Box lunch fee \*Tentative: 1,760 JPY/box (Incl. tax) with paper-packed green tea. The secretariat will invoice separately.)  
Please note that food and drink prices may be subject to change due to price increases.
- 4) Hospitality fees: Transportation including travel, honoraria, lodging, etc., for speakers and chairs.
- 5) Signage: Signs in front of the room, name boards, etc. / Visuals: Recording, etc.
- 6) Anteroom: Anterooms will not be provided for each co-host and will be shared among multiple co-hosts.  
We appreciate your understanding.

**If you are considering applying for both the Exhibition Plan (Prime/Standard) and the MBSJ Package, please contact the secretariat.**

Biotechnology (luncheon) seminars will be co-hosted by companies and MBSJ as part of the annual meeting program.

<b>Date</b>	<p><b>December 3 – 5, 2025 11:40 – 12:30 *Tentative</b></p> <p>Presentation time: <b>50 minutes</b> (During lunch time)</p> <p>4 to 6 seminars will be held in parallel each day. Subject to change depending on the number of applications.</p> <p>* Time slot may change slightly due to scheduling adjustments.</p> <p>* As a general rule, seminar date requests will be considered on a first-come, first-served basis. However, please note that fulfilling such requests may not always be possible due to program constraints.</p>
<b>Venue</b>	Conference Center, Pacifico Yokohama
<b>Eligibility</b>	As a general rule, exhibitors * Fee varies for non-exhibitors.
<b>Number of Slots Available</b>	Up to 18 slots
<b>Format</b>	On-site only
<b>Fee</b>	<ul style="list-style-type: none"> <li>● Exhibitor: <b>1,155,000 JPY</b> (Incl. tax) + Lunch * Lunch is not included.</li> <li>● Non-exhibitor: <b>1,370,000 JPY</b> (Incl. tax) + Lunch * Lunch is not included.</li> </ul> <p>&lt; Universities, public research institutions, university venture companies are eligible to apply for Academic type below. &gt;</p> <ul style="list-style-type: none"> <li>● Academic type: <b>880,000 JPY</b> (Incl. tax) Lunch included 100 box lunches are included in the academic type fee.</li> </ul> <p>* If you wish to make the seminar content available on a viewing platform at a later date, an additional fee will apply.</p>
<b>Application</b>	<p>Please apply via the online application form on the annual meeting website.</p> <p>Multiple companies may apply for a single seminar slot. Please contact the secretariat in such a case.</p>
<b>Application Deadline</b>	<b>June 30, 2025 *Tentative</b>

### Distribution of seminar tickets

Currently under consideration for **advance reservations and on-site distribution** (as of December, 2024; subject to change due to operational reasons).

The lunch boxes for the Biotechnology Seminar will be distributed in exchange for seminar tickets.

\* The co-hosts will be provided with the registration information of those who have made advance reservations for the seminar.

### What is included in the fee

- 1) Room fee
- 2) Basic equipment and facilities (LCD projector, screen, audio equipment, and laser pointer)
- 3) 2 operation support staff: For projection operation, time keeping, and lighting
- 4) Equipment: Desk light, bell, stopwatch, and a table for distributing handouts, box lunches, etc.
- 5) 3 meeting passes  
\* Note: If the requested speaker is a member of MBSJ, we kindly ask that the speaker complete their registration.
- 6) 10 staff badges (Separate from the exhibitor badges).

If more than one company applies for the same slot, items 5) and 6) above will be distributed to the representative company.

### What is NOT included in the fee

- 1) Equipment for filming and recording.  
Please bring your own PC for the presentation and ensure the LCD projector connection and functionality are checked.
- 2) Operation staff: For distributing box lunches and making announcements.
- 3) Food and drink: The quantity will be determined by the co-hosting companies, and the secretariat will place a bulk order accordingly.  
(Box lunch fee \*Tentative: 1,760 JPY/box (Incl. tax) with paper-packed green tea. The secretariat will invoice separately.)  
Please note that food and drink prices may be subject to change due to price increases.
- 4) Hospitality fees: Transportation including travel, honoraria, lodging, etc., for speakers and chairs.
- 5) Signage: Signs in front of the room, name boards, etc. / Visuals: Recording, etc.
- 6) Anteroom: Anterooms will not be provided for each co-host and will be shared among multiple co-hosts.  
We appreciate your understanding.



Biotechnology short seminars will be co-hosted by companies and MBSJ as part of the annual meeting program.

	<p><b>December 3 – 5, 2025 11:40 – 12:10 *Tentative</b>            Presentation time: <b>30 minutes</b> (During lunch time)</p>
<b>Date</b>	<p>* Time slot may change slightly due to scheduling adjustments.            * As a general rule, seminar date requests will be considered on a first-come, first-served basis. However, please note that fulfilling such requests may not always be possible due to program constraints.</p>
<b>Venue</b>	Short presentation booth (Approx. 40 seats), Exhibition Hall, Pacifico Yokohama
<b>Number of Slots Available</b>	<p>10 slots per day (Total: 30 slots) *Tentative            If the two seminars are scheduled concurrently on the same day, time slots may be divided into a first-half and second-half session. Thank you for understanding.</p>
<b>Format</b>	On-site only
<b>Fee</b>	<ul style="list-style-type: none"> <li>● Exhibitor: <b>253,000 JPY</b> (Incl. tax) + Lunch &amp; snacks                * Lunch and snacks are not included.</li> <li>● Non-exhibitor: <b>418,000 JPY</b> (Incl. tax) + Lunch &amp; snacks                * Lunch and snacks are not included.</li> </ul>
<b>Application</b>	<p>Please apply via the online application form on the annual meeting website.            Multiple companies may apply for a single seminar slot. Please contact the secretariat in such a case.</p>
<b>Application Deadline</b>	<b>June 30, 2025 *Tentative</b>

### Distribution of seminar tickets

Currently under consideration for **distribution on a first-come, first-served basis in front of the room on the day of the seminar.**(as of December, 2024; subject to change due to operational reasons).

Boxed lunches and snacks will be provided to participants upon showing their meeting badges.

\* Participant information for the Biotechnology Short Seminar will not be shared with the co-hosts.

### What is included in the fee

- 1) Room fee
- 2) Basic equipment and facilities (LCD projector, screen, audio equipment, and laser pointer)
- 3) Equipment: Bell, stopwatch, and a table for distributing handouts, box lunches, etc.
- 4) 1 meeting pass  
\* Note: If the requested speaker is a member of MBSJ, we kindly ask that the speaker complete their registration.
- 5) 4 staff badges (Separate from the exhibitor badges).

If more than one company applies for the same slot, items 4) and 5) above will be distributed to the representative company.

### What is NOT included in the fee

- 1) Equipment other than those listed above, such as equipment for filming and recording.  
Please bring your own PC for the presentation and ensure the LCD projector connection and functionality are checked.
- 2) Operation staff: For distributing box lunches and making announcements.
- 3) Food and drink: The quantity will be determined by the co-hosting companies, and the secretariat will place a bulk order accordingly.  
(Box lunch fee \*Tentative: 1,760 JPY/box (Incl. tax) with paper-packed green tea. The secretariat will invoice separately.)  
Please note that food and drink prices may be subject to change due to price increases.
- 4) Hospitality fees: Transportation including travel, honoraria, lodging, etc., for speakers and chairs.
- 5) Signage: Signs in front of the room, name boards, etc. / Visuals: Recording, etc.
- 6) Anteroom

Night café seminars will be co-hosted by companies and MBSJ as part of the annual meeting program.

	<p><b>December 3 – 4, 2025 19:15 – 20:15 *Tentative</b>            Presentation time: <b>60 minutes</b> (Scheduled during the matching event.)</p>
<b>Date</b>	<p>* Time slot may change slightly due to scheduling adjustments.            * As a general rule, seminar date requests will be considered on a first-come, first-served basis. However, please note that fulfilling such requests may not always be possible due to program constraints.</p>
<b>Venue</b>	Short presentation booth (Approx. 40 seats), Exhibition Hall, Pacifico Yokohama
<b>Number of Slots Available</b>	<p>1 slot per day (Total: 2 slots) *Tentative            If the two seminars are scheduled concurrently on the same day, time slots may be divided into a first-half and second-half session. Thank you for understanding.</p>
<b>Format</b>	On-site only
<b>Fee</b>	<p>● Exhibitor: <b>220,000 JPY</b> (Incl. tax) + Snacks &amp; Drinks            * Snacks and drinks are not included.</p> <p>● Non-exhibitor: <b>385,000 JPY</b> (Incl. tax) + Snacks &amp; Drinks            * Snacks and drinks are not included.</p>
<b>Application</b>	<p>Please apply via the online application form on the annual meeting website.            Multiple companies may apply for a single seminar slot. Please contact the sponsorship secretariat in such a case.</p>
<b>Application Deadline</b>	<b>June 30, 2025 *Tentative</b>

Snacks and drinks will be provided to participants upon showing their meeting badges.

\* Participant information for the seminar will not be shared with the co-hosts.

### What is included in the fee

- 1) Room fee
- 2) Basic equipment and facilities (LCD projector, screen, audio equipment, and laser pointer)
- 3) Equipment: Bell, stopwatch, and a table for distributing handouts, snacks, etc.
- 4) 1 meeting pass  
\* Note: If the requested speaker is a member of MBSJ, we kindly ask that the speaker complete their registration.
- 5) 4 staff badges (Separate from the exhibitor badges).

If more than one company applies for the same slot, items 4) and 5) above will be distributed to the representative company.

### What is NOT included in the fee

- 1) Equipment other than those listed above, such as equipment for filming and recording.  
Please bring your own PC for the presentation and ensure the LCD projector connection and functionality are checked.
- 2) Operation staff: For distributing snacks and drinks and making announcements.
- 3) Food and drink: The quantity will be determined by the co-hosting companies, and the secretariat will place a bulk order accordingly.  
(Snack fee \*Tentative: 1,430 JPY/set (Incl. tax) The secretariat will invoice separately.)  
Please note that food and drink prices may be subject to change due to price increases.
- 4) Hospitality fees: Transportation including travel, honoraria, lodging, etc., for speakers and chairs.
- 5) Signage: Signs in front of the room, name boards, etc. / Visuals: Recording, etc.
- 6) Anteroom

## Exhibition

### 【 Basic Information 1 】

<b>Date</b>	December 3-5, 2025 11:00 – 19:00 *Tentative
<b>Venue</b>	Exhibition Hall, Pacifico Yokohama * Poster presentations will be held at the same venue.
<b>Applicable Exhibits</b>	Instruments, reagents, products and services related to life science research Joint usage, introduction, and recruitment of universities and research institutions Related books
<b>Application</b>	<p><b>Please apply via the online application form on the annual meeting website.</b></p> <p>Your application will be considered complete upon receiving both (1) and (2) below.</p> <p>(1) A confirmation email will be sent after you submit your application.</p> <p>(2) Then, another email confirming the receipt of your application will be sent from the secretariat.</p> <p>Please note that applications from unrelated companies will be reviewed by the organizing committee to determine eligibility.</p> <ul style="list-style-type: none"> <li>• <b>An invoice will be sent after the application is accepted.</b></li> <li>• <b>Please make the payment by the due date specified on the invoice.</b></li> <li>• <b>Bank transfer fees will be borne by the exhibitors.</b></li> </ul>
<b>Application Deadline</b>	<p>The application deadline varies depending on the plan. For more details, please refer to the respective pages.</p> <p>If the number of applications reaches the available booths, the application will be closed even before the deadline.</p>
<b>Payment Due Date</b>	<p>Please be sure to notify us if the payment cannot be made by the due date. If we do not receive the payment by the due date without notice, your application will be considered cancelled and you will be required to pay a cancellation fee.</p>
<b>Contact</b>	<p>MBSJ2025 Sponsorship secretariat (c/o A &amp; E Planning, Co., Ltd.) 4F, Hitotsubashi Bekkan, 2-4-4, Hitotsubashi, Chiyodaku, Tokyo 101-0003 Phone: +81-3-3230-2744 Email: <a href="mailto:e_25mbsj@aeplan.co.jp">e_25mbsj@aeplan.co.jp</a></p>

## Exhibition

### 【 Basic Information 2 】

#### Online abstracts

Exhibitors will be provided with account information for viewing online abstracts.

\* Please note that we may not produce online abstracts or may change its function, and in that case, account information will not be provided.

#### Meeting pass

Type A · AS: 1 meeting pass will be provided.

Even if you apply for more than one booth, you will receive 1 meeting pass.

Type AR · B · C · CS : No meeting pass will be provided.

\* The exhibition is part of the meeting and only open to participants of the meeting. No invitation will be issued.

\* Admission tickets for the exhibition will be sold during the meeting.

#### Dates of move-in / move-out

Move-in: December 2, 2025 14:00 - 18:00

Move-out: December 5, 2025 19:00 -

\* The above schedule is tentative, please be sure to check the confirmation which will be sent around 1.5 months to 2 months before the meeting.

## Cancellation

After an application has been accepted, cancellations are generally not allowed unless the Organizing Committee determines that the cancellation is due to force majeure. If the Organizing Committee approves the cancellation, the applicant must submit a written explanation of the cancellation reasons. The cancellation fee will be calculated based on the date the cancellation notice is received.

### [Cancellation Fees]

#### ◆ For applications during the primary application period

After application and before the primary deadline ... **50%** of the invoiced amount

On or after the primary deadline (after the start of the secondary application period) ... **100%** of the invoiced amount

#### ◆ For applications during the secondary application period

After application and before the secondary deadline ... **50%** of the invoiced amount

On or after the secondary deadline ... **100%** of the invoiced amount

## Booth Allocation

After the application deadline, the booth allocation will be arranged by the secretariat, taking into account the type, shape, weight, and number of booths. The booth layout will be sent approximately 1.5 months to 2 months before the meeting. Please note that no changes to the booth allocation will be accepted after it has been finalized.

## Booth Decoration and Changes / Equipment Rental

You can apply for booth decoration, alterations, electricity, and equipment rentals via the Exhibition Options Form. The form will be available approximately 1.5 to 2 months before the meeting.

## Management of Exhibits

Please note that exhibitors are responsible for the management of their own exhibits, and the secretariat will not be liable for any damage caused by force majeure, such as theft, loss, or fire during the exhibition period.

## Exhibition ★ Prime / Standard Plan

**Boosted PR effectiveness by standing out from other booths.**

Two types of plans are available for companies looking to advertise extensively.

### Prime Plan

		<div style="border: 1px solid black; padding: 2px; display: inline-block;">7.04 million JPY ⇒33%OFF!</div> <b>Prime Type A</b> <b><u>4,730,000JPY</u></b> (Incl. tax) * with fixtures <b>5,170,000JPY</b> (Incl. tax)	<div style="border: 1px solid black; padding: 2px; display: inline-block;">5.28 million JPY ⇒30%OFF!</div> <b>Prime Type B</b> <b><u>3,740,000JPY</u></b> (Incl. tax) * with fixtures <b>4,070,000JPY</b> (Incl. tax)	
Details	Exhibition booth	<b>8 booths</b>	<b>6 booths</b>	
	★Business Lounge	<b>Space equivalent to 6 booths</b>		
		<Fixtures> Image on page 16 • Lounge set (1 round table, 4 chairs) • Wall panels (L-shape) color / Punch carpet color: Black * If your company sets up a lounge without fixtures, the fee will be the upper amount.		
	Booth Allocation ★Highest Priority	<b>Main Street</b>	<b>Sub-Main Street</b>	
		Companies will select their booth locations in descending order of total application amount from areas near the exhibition hall entrance designated by the secretariat. (For applications with the same total, priority will be determined by the order of submission.) * Please contact the secretariat for details regarding specific street locations.		
Others	① Photo Spot Advertisement – Large size (See page 23 for details.) ② Advertisement in front of the exhibition hall (See page 17 for details.)			
Number of Slots Available	Up to 2 slots for each.			
Application	Please apply via the online application form on the annual meeting website.			
Application Deadline	<b>June 30, 2025 *Tentative</b>			

### Standard Plan

		<div style="border: 1px solid black; padding: 2px; display: inline-block;">2.23 million JPY ⇒17%OFF!</div> <b>Standard Type A</b> <b><u>1,870,000JPY</u></b> (Incl. tax)	<div style="border: 1px solid black; padding: 2px; display: inline-block;">1.79 million JPY ⇒17%OFF!</div> <b>Standard Type B</b> <b><u>1,485,000JPY</u></b> (Incl. tax)
Details	Exhibition booth	<b>4 booths</b>	<b>3 booths</b>
	Booth Allocation Priority	<b>You can choose your preferred location from the booth layout.</b> * Except for the Prime Plan locations.	
		Companies will select their booth locations in descending order of total application amount. (For applications with the same total, priority will be determined by the order of submission.)	
Others	① 1 Exhibitor Seminar A 15-minute seminar can be organized during the poster presentations on either the first or second day. Please be advised that requests for the seminar date cannot be fulfilled. ② Photo Spot Advertisement – Small size (See page 23 for details.) ③ Advertisement in front of the exhibition hall (See page 17 for details.)		
Number of Slots Available	Up to 4 slots for each.		
Application	Please apply via the online application form on the annual meeting website. Multiple companies may apply for a single seminar slot. Please contact the sponsorship secretariat in such a case.		
Application Deadline	<b>June 30, 2025 *Tentative</b>		

## Exhibition ★ Prime / Standard Plan

## Lounge Image

8 booths for exhibits and 6 booths for the lounge area



## Exhibitor Seminar Image

A 15-minute seminar can be organized in the short presentation area of the exhibition hall. This provides a valuable opportunity for promoting your products or services. The secretariat will schedule the seminar during the poster session periods to maximize attendee traffic.

<Short presentation area>

Monitor / Microphone / Chairs / Counter for PC will be prepared.

\* The photo below is different from the Exhibitor seminar.





Advertisement in front of the exhibition hall

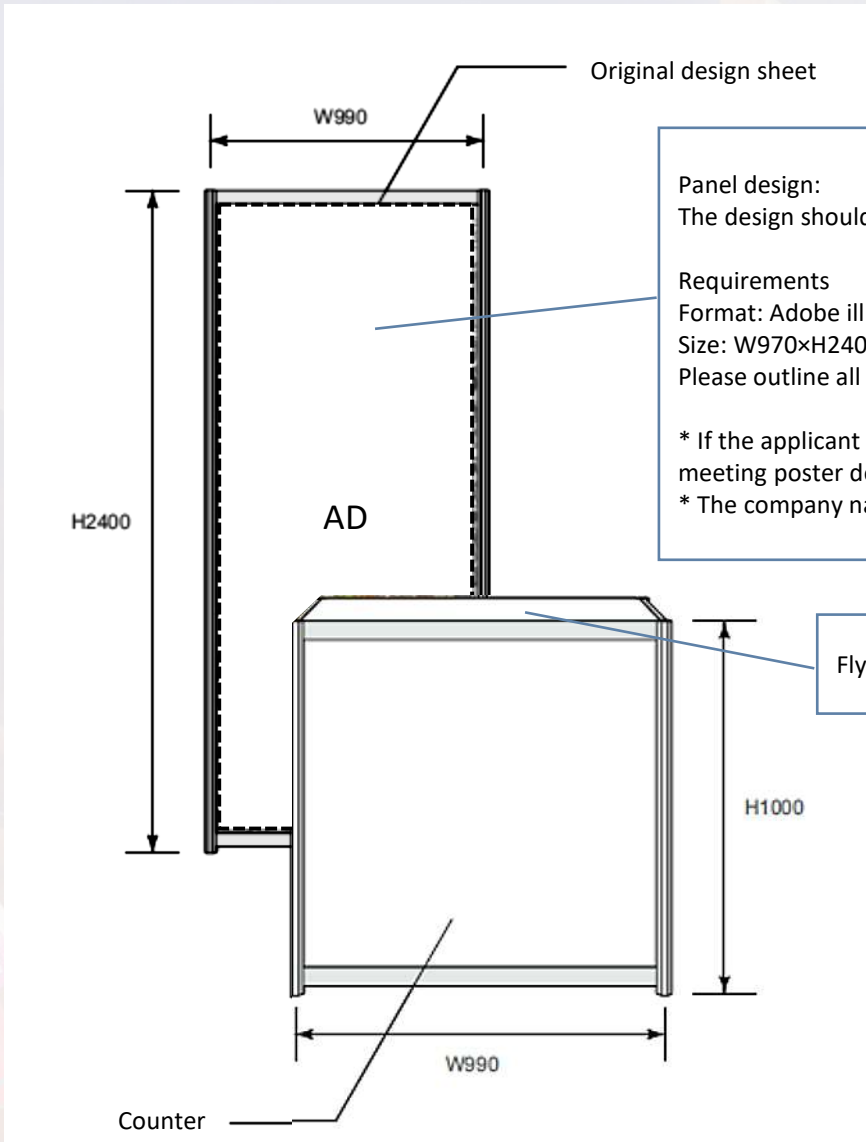

Panel design:  
The design should be created by the applicant.

Requirements  
Format: Adobe illustrator  
Size: W970×H2400  
Please outline all fonts and embed all images.

\* If the applicant does not submit a design, the meeting poster design will be used.  
\* The company nameplate can be removed.

Flyers and brochures can be placed.

# Exhibition - Basic Plan

A / B / C

**Application deadline:** Primary **June 30, 2025 (Tentative)**

Secondary **July 31, 2025 (Tentative)**

\* If the number of applications reaches the number of available booths, the application will be closed even before the deadline.

**Number of booth available:** 350 booths

## Basic Booth Layout Image

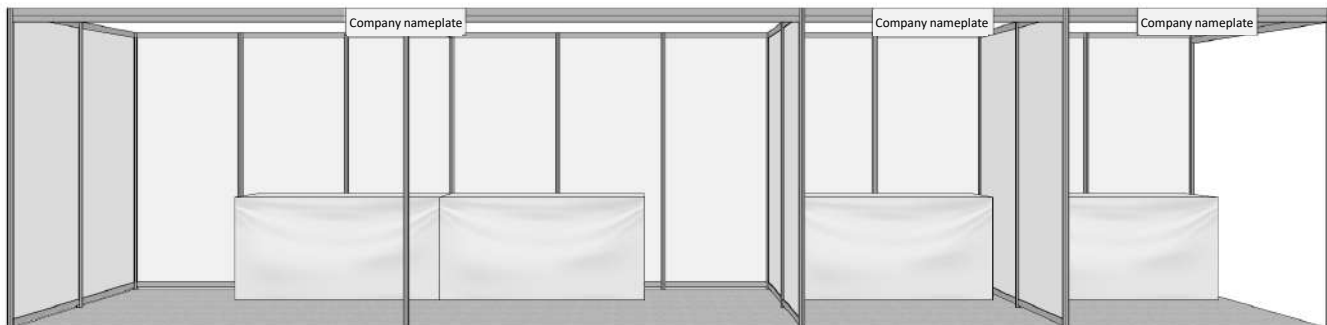

## Type A

**Fee:** Primary **440,000 JPY/booth** (Incl. tax)  
Secondary **462,000 JPY/booth** (Incl. tax)

**Applicable exhibits:**

Instruments, reagents, products and services related to life science research  
Joint usage, introduction, and recruitment of universities and research institutions

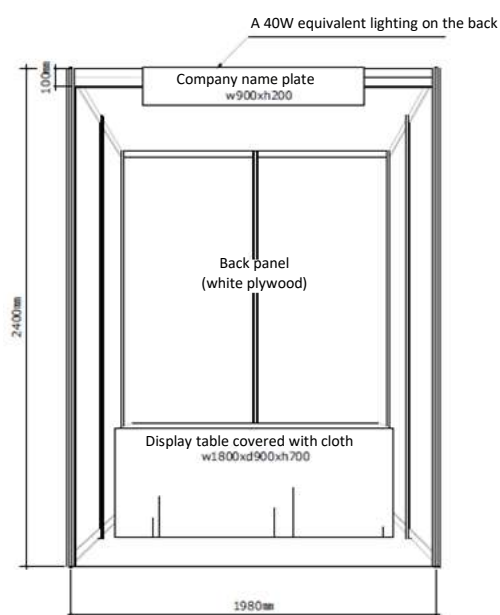

- Size: W1,980 x D1,980 x H2,400 mm
  - Fixtures : Display table (W1,800×D900×approx.H700mm), Company name plate, Lighting (40W equivalent) and 1 chair (2 chairs for 4 booths).
  - Back and side panels are system panels. The tabletop is covered with white cloth, and the sides are wrapped with white cloth.
  - Booth locations cannot be specified. If you wish to have adjacent booths with a partner company, **mutual agreement is required**. For cross-aisle booths (6 or more booth application required) or peninsula booths (4 or more booth application required for 3 sides open), please contact the secretariat.
  - Carpets must not exceed the booth dimensions and cannot be placed in aisles, even for cross-aisle booths.
- ◆ 1 meeting pass will be provided to the Type A exhibitors, regardless of the number of booths applied for.
- ◆ 5 exhibitor badges per booth will be provided.

**Application is required to use electricity.** If you need electricity, please submit your application via the exhibition options form, which will be provided after the deadline. Electricity and electrical installation fees are the responsibility of the exhibitor.

Type B

**Fee:** Primary **132,000 JPY/booth** (Incl. tax)  
Secondary **154,000 JPY/booth** (Incl. tax)

**Applicable exhibits:**  
Books related to life science research  
Publishers, bookstores, and translation / proofread services related to life science research

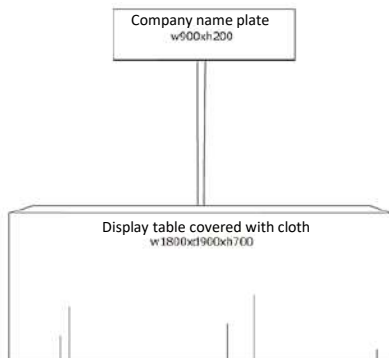

- Size: W1,800 x D900 x H700 mm
- Fixtures: Display table (W1,800×D900×approx.H700mm), Company name plate and 1 chair (2 chairs for 4 booths).
- The tabletop is covered with white cloth, and the sides are wrapped with white cloth.
- ◆ No meeting pass will be provided to Type B exhibitors.
- ◆ 5 exhibitor badges per booth will be provided.

**Application is required to use electricity.** If you need electricity, please submit your application via the exhibition options form, which will be provided after the deadline. Electricity and electrical installation fees are the responsibility of the exhibitor.

Type C

**Fee:** Primary **264,000 JPY/booth** (Incl. tax)  
Secondary **286,000 JPY/booth** (Incl. tax)

**Applicable exhibits:**  
Universities and research institutions of public organizations are eligible to exhibit under Type C. University-originated venture companies are also eligible, but only those that have been in business for less than five years and qualify as small and medium-sized enterprises according to Article 2 of the Small and Medium-Sized Enterprise Basic Act (Act No. 154, July 20, 1963), in addition to displaying the university name on the company name plate.

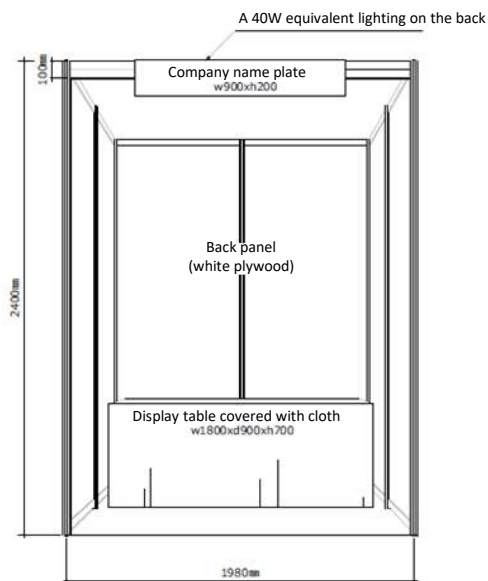

- Size/Fixtures: Equivalent to Type A
- Booth allocation will be arranged by the secretariat after the application deadline.
- Booth locations cannot be specified. If you wish to have adjacent booths with a partner company, mutual agreement is required.
- Carpets must not exceed the booth dimensions and cannot be placed in aisles, even for cross-aisle booths.
- ◆ No meeting pass will be provided to Type C exhibitors.
- ◆ 5 exhibitor badges per booth will be provided.

**Application is required to use electricity.** If you need electricity, please submit your application via the exhibition options form, which will be provided after the deadline. Electricity and electrical installation fees are the responsibility of the exhibitor.

A 15-minute seminar can be organized in the short presentation area of the exhibition hall. This provides a valuable opportunity for promoting your products or services. (Please refer to page 16.) The secretariat will schedule the seminar during the poster session periods to maximize attendee traffic.

**Application deadline:** Primary **June 30, 2025 (Tentative)**  
 Secondary **July 31, 2025 (Tentative)**

### Type AS

**Fee:** Primary **528,000 JPY/booth** (Incl. tax)  
 Secondary **539,000 JPY/booth** (Incl. tax)

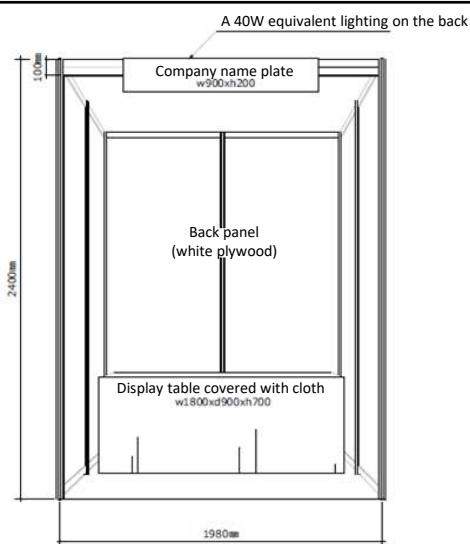

**Booth specifications / Applicable exhibits:**  
 Same as Basic plan - Type A.

### Type CS

**Fee:** Primary **352,000 JPY/booth** (Incl. tax)  
 Secondary **352,000 JPY/booth** (Incl. tax)

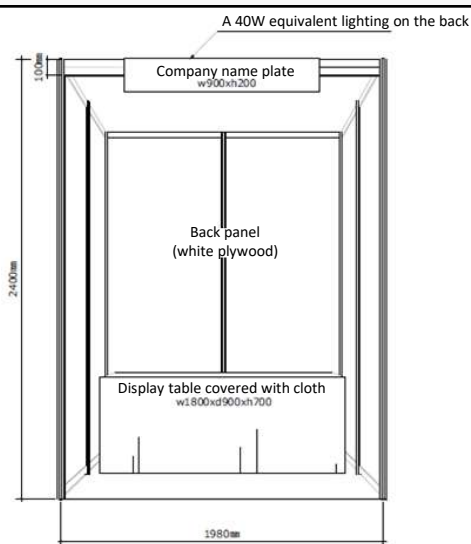

**Booth specifications / Applicable exhibits:**  
 Same as Basic plan - Type C.

### Seminar time

One 15-minute seminar can be held per booth application. If you apply for multiple booths, the seminar time can be extended according to the number of booths.

e.g. 2-booth application → 1 seminar (30 min)  
 2 seminars (15 min × 2)

The seminar schedule will be set by the secretariat during one of the poster session time slots from December 3 to 5. Please note that we are unable to accommodate specific date requests.

## Exhibition - New Exhibitor Plan

### \*Exclusive to First-Time Sponsoring Companies

AR

We have prepared a special plan to encourage participation from many companies. We will set up a "New Exhibitor Special Zone (tentative name)" to gather first-time exhibitors, and the exhibition fees for this special zone will be discounted. We hope many companies will participate and help make the exhibition more vibrant. Eligible companies are encouraged to take advantage of this opportunity.

**Application deadline:** Primary **June 30, 2025 (Tentative)**  
Secondary **July 31, 2025 (Tentative)**

**Fee:** Primary **385,000 JPY/booth** (Incl. tax) / Secondary **440,000 JPY/booth** (Incl. tax)

#### Eligibility / Applicable exhibits:

- Companies that have never exhibited at past annual meetings
- Instruments, reagents, products and services related to life science research  
Joint usage, introduction, and recruitment of universities and research institutions

#### Conditions:

- The booths will be placed within the "New Exhibitor Special Zone (tentative name)". The special zone will be set up by the secretariat after the application deadline, and no specific placement requests will be accepted.
- If the secretariat determines that the company does not meet the criteria after application, the exhibition fee will be adjusted to the Type A rate and invoiced accordingly. Please note that the confirmation of your application may take some time.
- The maximum number of booths per company is limited to 3.

#### ◆Size / Specifications:

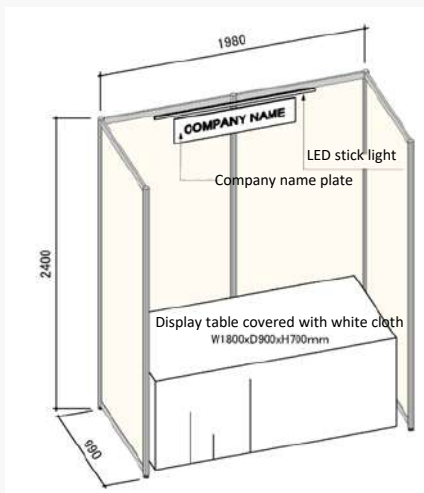

- Size: W1,980 x D990 x H2,400 mm
  - Fixtures : Display table (W1,800xD900×approx.H700mm), Company name plate, Lighting (40W equivalent) and 1 chair (2 chairs for 4 booths).
  - Back and side panels are system panels. The tabletop is covered with white cloth, and the sides are wrapped with white cloth.
  - Booth locations cannot be specified. If you wish to have adjacent booths with a partner company, [mutual agreement is required](#).
  - Carpets must not exceed the booth dimensions and cannot be placed in aisles, even for cross-aisle booths.
- ◆ No meeting pass will be provided.  
◆ 5 exhibitor badges per booth will be provided.

**Application is required to use electricity.** If you need electricity, please submit your application via the exhibition options form, which will be provided after the deadline. Electricity and electrical installation fees are the responsibility of the exhibitor.

## Dedicated Sponsors Over The Years

To companies that have exhibited for many years, from 2020 (Online) to 2025, we would like to express our sincere gratitude by offering two complimentary benefits. We hope you take advantage of this opportunity. (\* Application is required.)

For more details, please refer to the guidelines below.

**\* Please note that these benefits are not automatically applied. Companies wishing to receive these benefits must apply accordingly.**

<b>Eligibility</b>	Companies that have exhibited at the annual meetings from the 43rd (2020) to the 47th (2024), and are also exhibiting at the 48th annual meeting (2025).
<b>Benefits</b>	<p>1. Special Signboard (Logo Placement)</p> <ul style="list-style-type: none"> <li>↳ Signboard Size: 1800mm x 1800mm</li> <li>↳ Location: Near the entrance of the exhibition hall</li> </ul> <p>▼Image</p>  <p>2. Flyer Distribution</p> <ul style="list-style-type: none"> <li>* A table will be set up near the entrance of the exhibition hall for flyer distribution.</li> </ul>
<b>Logo Data</b>	<p>Logo</p> <ul style="list-style-type: none"> <li>・Adobe Illustrator (.ai)</li> <li>・Please outline all fonts and embed all images.</li> </ul> <p>Flyer</p> <ul style="list-style-type: none"> <li>・Please bring the flyers either by mail in advance or to the registration desk on the day of the meeting.</li> </ul>
<b>Application</b>	<p>Please apply via the online application form on the annual meeting website.</p> <p>* Please note that these benefits are not automatically applied. Companies wishing to receive these benefits must apply accordingly.</p>
<b>Application Deadline</b>	<b>Early September, 2025</b>
<b>Data Submission Deadline</b>	September 19, 2025 * Tentative

## Advertising Opportunities

We are accepting applications for the following types of advertisements. We encourage you to take advantage of these opportunities to promote your business.

### Photo Spot Advertisement

A photo spot will be set up near the entrance to the poster and exhibition area, and we are accepting applications for company and organization logos to be displayed. This spot will attract many participants taking photos during the meeting, making it an excellent promotional opportunity.

<b>Number of Slots Available</b>	Large size - 3 slots / Small size -3 slots
<b>Fee</b>	<b>Large size - 330,000 JPY/slot</b> <b>Small size - 220,000 JPY/slot</b>
<b>Image</b>	
<b>Details</b>	Logo placement on the back panel and flyer distribution.
<b>Logo Size</b>	Large size - W600mm×H700mm / Small size - W400mm×H500mm
<b>Logo Data</b>	Adobe Illustrator (.ai) Please outline all fonts and embed all images.
<b>Application Deadline</b>	<b>Early September, 2025</b>
<b>Data Submission Deadline</b>	September 19, 2025 * Tentative

## Advertising Opportunities

### Signboard Advertisement in front of Lecture Rooms

Advertisements will be displayed on the signage in front of all lecture rooms (Conference center). As it will be seen by many participants throughout the meeting, please take advantage of this opportunity for promotion.

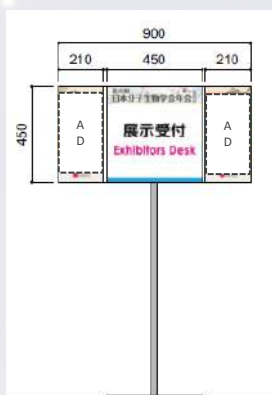

<b>Number of Slots Available</b>	2 slots
<b>Ad Size</b>	W210mm×H450mm (Equivalent to A4 size)
<b>Fee</b>	<b>165,000 JPY (Incl. tax) /slot</b>
<b>Ad Data</b>	Adobe Illustrator (.ai) Please outline all fonts and embed all images.
<b>Application Deadline</b>	<b>Early September, 2025</b>
<b>Data Submission Deadline</b>	September 19, 2025 * Tentative

### Wi-Fi Signboard Advertisement

Advertisements will be displayed on the Wi-Fi password information signs. These signs will be seen by many participants during the meeting, so please take advantage of this opportunity for promotion.

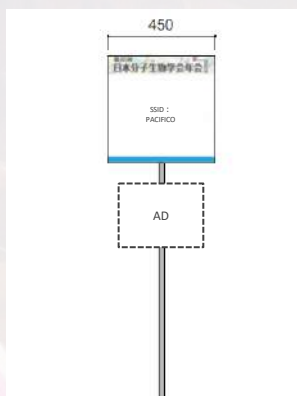

<b>Number of Slots Available</b>	1 slot
<b>Ad Size</b>	W420mm×H297mm (Equivalent to A3 size)
<b>Fee</b>	<b>220,000 JPY (Incl. tax) /slot</b>
<b>Ad Data</b>	Adobe Illustrator (.ai) Please outline all fonts and embed all images.
<b>Application Deadline</b>	<b>Early September, 2025</b>
<b>Data Submission Deadline</b>	September 19, 2025 * Tentative

### Exhibition Hall Map Advertisement

We are accepting advertisements to be placed on the map posted near the entrance of the exhibition hall. The map will be used by participants to check poster numbers during the meeting, making it a great opportunity to promote your booth.

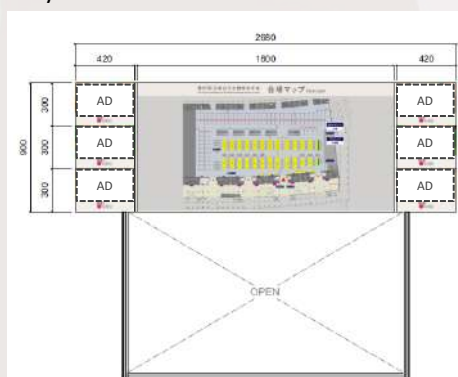

<b>Number of Slots Available</b>	6 slots
<b>Ad Size</b>	W420mm×H300mm (Equivalent to A3 size)
<b>Fee</b>	<b>220,000 JPY (Incl. tax) /slot</b>
<b>Ad Data</b>	Adobe Illustrator (.ai) Please outline all fonts and embed all images.
<b>Application Deadline</b>	<b>Early September, 2025</b>
<b>Data Submission Deadline</b>	September 19, 2025 * Tentative



## Screen Advertisement

We are accepting screen advertisements to be projected during times when the screens are not in use for symposia, workshops, etc.



<b>Number of Slots Available</b>	20 slots * Tentative
<b>Projection Times</b>	30 seconds/slot
<b>Fee</b>	<b>110,000 JPY/slot</b> (Incl. tax) <b>88,000 JPY/slot</b> (Incl. tax) from the 2 <sup>nd</sup> slot * A 60-second slot is available by connecting 2 slots.
<b>Ad Data</b>	MP4 (Aspect ratio 16:9)
<b>Application Deadline</b>	<b>Early September, 2025</b>
<b>Data Submission Deadline</b>	September 19, 2025 * Tentative

## Push Pin Container Sponsor

Ads will be printed on push pin containers used for poster presentations.

- Ads can be printed on paper cups and a bookmark-sized flyer can be inserted.
- By including campaign information on the flyer, you can effectively promote your company to poster presenters.



<b>Number of Slots Available</b>	3 slots
<b>Fee</b>	<b>88,000 JPY/slot</b> (Incl. tax) * Paper cups and flyer production costs will be incurred. If there are multiple applications, the number of paper cups for advertising will be divided among the applicants according to the number of poster presentations.
<b>Application Deadline</b>	When application reaches 3. * Delivery deadline for paper cups and flyers: 1 week before the first day of the meeting

## Banner Advertisement on the Annual Meeting Website



<b>Number of Slots Available</b>	Up to 10 banners
<b>Ad Size</b>	W 200 px x H 80 px
<b>Fee</b>	<b>220,000 JPY/banner</b> (Incl. tax)
<b>Ad Data</b>	Image file: GIF (Animation and infinite loop available), JPEG * Please send the URL to be linked to the banner as well. The submitted ad can be replaced once.
<b>Application Deadline</b>	When application reaches 10.
<b>Data Submission Deadline</b>	October 25, 2025 *Tentative

## Advertising Opportunities

### Spot Advertising before and after Lectures

Spot advertising opportunities are available, allowing you to play a video or give a presentation before or after each symposium. Videos or presentations can be used for promoting your company or products, introducing your exhibition booth, and more.

Additionally, you may distribute flyers at the entrance of the room.

This sponsorship option offers a highly targeted approach, as you can choose the symposium where you would like to play your video or give your presentation, effectively reaching researchers in your field.

**\* Please refer to the annual meeting website for the details of symposia.**

<b>Details</b>	<ul style="list-style-type: none"> <li>• Only one company per symposium will have the exclusive opportunity to play a video or give a presentation. You can choose either “3 minutes before the symposium” or “3 minutes before + 1 minute after the symposium.”</li> <li>• Symposium assignments will be made on a first-come, first-served basis. (Even with a sponsorship application, priority will be given to those who have made an earlier selection.)</li> <li>• It is possible to apply for multiple symposia.</li> <li>• Flyer distribution and placement in front of the room are also allowed.</li> </ul>
<b>Presentation Format</b>	<ul style="list-style-type: none"> <li>• Any presentation format is acceptable as long as it fits within the allotted time. <ul style="list-style-type: none"> <li>e.g. Play a pre-recorded video on the screen for 1 minute, followed by a 2-minute presentation.</li> <li>e.g. Give a 3-minute presentation using PowerPoint.</li> </ul> </li> <li>• Language: Presentations can be in either Japanese or English.</li> <li>• Please bring your own PC.</li> <li>• Flyers may be distributed in front of the room.</li> <li>• The secretariat can also project pre-recorded videos upon request. (For details, please contact the secretariat.)</li> </ul>
<b>Fee</b>	<p>3 minutes before + 1 minute after the symposium: <b>110,000 JPY/slot</b> (Incl. tax)</p> <p>3 minutes before the symposium: <b>88,000 JPY/slot</b> (Incl. tax)</p>
<b>Application Deadline</b>	<b>Early September, 2025</b>
<b>Data Submission Deadline</b>	September 19, 2025 * Tentative
<b>Application</b>	<p><b>Please apply via the online application form on the annual meeting website.</b></p> <p>Your application will be considered complete upon receiving both (1) and (2) below.</p> <p>(1) A confirmation email will be sent after you submit your application.</p> <p>(2) Then, another email confirming the receipt of your application will be sent from the secretariat.</p> <p>Please note that applications from unrelated companies will be reviewed by the organizing committee to determine eligibility.</p>

## Advertising Opportunities

### Email Marketing

<b>Email Recipients</b>	<p><b>Early registration participants</b></p> <p>Emails will be sent to all participants who have opted in to receive marketing emails during the registration process.</p>
<b>Fee</b>	<ul style="list-style-type: none"> <li>• Applicants for co-hosted seminar + exhibition: <b>110,000 JPY (Incl. tax)</b></li> <li>• Non-applicants for co-hosted seminar + exhibition: <b>165,000 JPY (Incl. tax)</b></li> </ul> <p>* Each company is limited to one slot. Multiple slots cannot be applied for.</p>
<b>Character Limit</b>	Up to 48 one-byte characters per line and up to 10 lines per email.
<b>Delivery Date</b>	<p>Any weekday in the 4th week of October or the 1st-2nd week of November after the early registration deadline.</p> <p>* Please note that email delivery is limited to one company per day. If another company has already applied for the same day, you will be asked to choose an alternative date.</p>
<b>Number of Distributions</b>	Only one email delivery per company.
<b>Notes</b>	<ul style="list-style-type: none"> <li>• Please send the text at least one week before the scheduled delivery date (two revisions will be accepted if corrections are needed).</li> <li>• Please make sure to include contact information (phone number or email address) in the signature at the end of the email text.</li> <li>• Be sure to include the applicant's company name in the subject line.</li> <li>• Proofreading will not be provided. Please check the content before submitting it.</li> <li>• Recipient information will not be shared.</li> </ul>
<b>Application Deadline</b>	<b>October, 2025 * Tentative</b>
<b>Text Deadline</b>	<b>October, 2025 * Tentative</b>
<b>Application</b>	<p><b>Please apply via the online application form on the annual meeting website.</b></p> <p>Your application will be considered complete upon receiving both (1) and (2) below.</p> <p>(1) A confirmation email will be sent after you submit your application.</p> <p>(2) Then, another email confirming the receipt of your application will be sent from the secretariat.</p> <p>Please note that applications from unrelated companies will be reviewed by the organizing committee to determine eligibility.</p>

## Pocket Program Advertisement

We are accepting advertisements for the pocket program. The pocket program will be available for both participants of MBSJ member and non-member, with an expected circulation of 8,000 copies.

We encourage you to take advantage of this opportunity for advertising.

### 【Overview】

Circulation	8,000 copies *Tentative
Date of Issue	Early October, 2025
Application Deadline	July 18, 2025
Ad Submission Deadline	July 25, 2025
Book Size	A5 (210mm height × 148mm width)
Application	Please apply via the online application form on the annual meeting website.
Ad Size	1 page: 180mm height × 125mm width 1/2 page: 85mm height × 125mm width Bleed : Not acceptable
Ad requirements	<ul style="list-style-type: none"> <li>• Black &amp; White or 4 colors</li> <li>• Please attach a print sample. (If 4-color, please attach a 4-color print sample.)</li> <li>• Print-ready data</li> </ul>

### Data Format: Adobe Illustrator (.ai)

- Please outline all fonts and embed all images.
- please specify the OS and the version of Illustrator used for creating the ad.
- Proofreading will be performed by the printer. Please note that a proof sheet will not be sent to you.

### 【Fee】

Page	Fee (Incl. Tax)
Cover 4 4 colors / 1 page	<b>220,000 JPY</b>
Cover 3 4 colors / 1 page	<b>176,000 JPY</b>
Cover 2 4 colors / 1 page	<b>198,000 JPY</b>
Back matter Black & White / 1 page	<b>88,000 JPY</b>
Back matter Black & White / 1/2 page	<b>55,000 JPY</b>
Back matter 4 colors / 1 page	<b>154,000 JPY</b>

